

# TWRAP™

## Fire Penetration Wrap



TWRAP™ is a 25mm thick foil-faced, fire protection wrap that has been engineered to provide insulation performance on service penetrations as required by the National Construction Code (NCC) and tested in accordance with AS1530.4-2014.



### KEY FEATURES



- Simple fixing requirements
- Up to 3 hours fire insulation performance
- Suitable for cables, cable trays and metal pipes
- Fully encapsulated wrap system
- Bio-soluble fibres
- Easily identified on site for certification
- Easy to wrap around smaller services
- Allows for adds moves and changes during the life of the building
- Tested for use with a range of Trafalgar Fire's penetration systems

### WHAT IS TWRAP™?



- 25mm thick foil-faced, fire protection wrap
- Used with penetration sealing systems
- Aluminium foil, fiberglass-reinforced outside layer completely encapsulates the core
- Strong - additional handling strength and tear resistance
- Resists mould growth
- Thoroughly tested to AS1530.4-2014

### TRADES

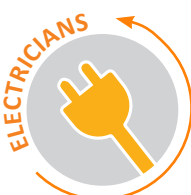

# TABLE OF CONTENTS



Section		Page
Benefits		3
Compliance		4
Fire Resistance Level		5
TWRAP™ Length		6-7
FyreFLEX® Sealant - Metal Pipes		8
FyreFLEX® Sealant - Electrical		9
FyrePEX Intumescent Sealnat   FyreCHOKE		10
FyrePLUG®   FyreBATT   FyreBOARD MAXILITE®		11
FyreSET® MORTAR		12
Installation	All Walls	13
	TWRAP™ - Cable Trays	14
System Range		15
Documentation		16
What about FyreWrap®?		17
More About TWRAP™		18
Product Specifications		19
Health & Safety		20
FyreWrap® & TWRAP™		21
FAQ		22
Technical Drawings	Walls Single TWRAP™ Length	23
	Floors Single TWRAP™ Length	24
	TWRAP™ Extended Length	25
	Double Layers	26

# TWRAP™ INSULATION SYSTEMS

## WHAT IS TWRAP™

TWRAP™ is a 25mm thick fully foil encapsulated, fire protection wrap engineered to provide insulation performance on service penetrations as required by the National Construction Code (NCC) and tested in accordance with AS1530.4-2014.

TWRAP™ must be used in conjunction with Trafalgar Fire’s parent penetration sealing systems to provide the integrity and insulation rating, for services that conduct heat through fire barriers such as metal pipes and cables.

The aluminium foil, fiberglass-reinforced outside layer completely encapsulates the core and provides additional handling strength, protection from tearing and provides a high resistance to mould growth.



## WHY IS TWRAP™ NEEDED?

If a fire were to break out within a fire compartment, the temperatures within that compartment can quickly reach 1000C. This heat can be conducted through any metal service penetrations, typically pipes, cables and cable tray, into the adjoining fire compartment.

The increased temperatures can ignite any combustible materials in close proximity to the service penetrations, allowing the fire to spread without flames directly breaching the fire barrier.

Service penetrations are essential in all modern buildings, and the building code (NCC) requires these penetrations to be fire stopped for integrity as well as insulation performance which is where TWRAP™ is required.



# TWRAP™ INSULATION SYSTEMS

## FIRE RATING – HOW IS FIRE PERFORMANCE MEASURED?

An FRL (fire resistance level) is a handy way of summarising the performance of a building element. It consists of 3 numbers, all given in minutes:

# 90/90/90



**Structural Adequacy**  
The ability of the building element to support the weight of adjacent building elements.  
ie: a brick wall supporting a concrete floor slab above.



**Integrity**  
The ability of an element to prevent the passage of flames and hot gasses.  
ie: a plasterboard wall remaining intact and not allowing holes to form.

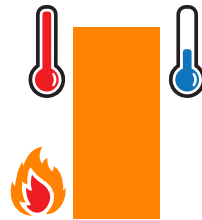

**Insulation**  
The ability of an element to resist heat transfer from the exposed face to the unexposed face.  
ie: a bundle of cables remaining below a set temperature limit on the unexposed side of the wall penetration system.

*Note: Penetrations are not required to have a Structural Adequacy rating and is usually expressed as a dash. For example, a penetration through a 2 hour load bearing wall would be written as -/120/120.*

### INTEGRITY

TWRAP™ will provide the insulation component of the FRL only, and so service penetrations must be fire stopped firstly with a system to achieve the integrity performance such as FyreBOARD MAXILITE®, FyrePLUG® Pillows, FyreBOX™, FyreSET® Mortar, FyreBATT or FyreFLEX® Sealant.

### INSULATION (TEMPERATURE RISE)

After a penetration is sealed for integrity using an approved Trafalgar Fire fire stopping product, TWRAP™ is required to be wrapped around the service for a certain distance to keep the temperatures under a safe level – and stop the spread of fire.

# COMPLIANCE



## COMPLIANCE WITH THE NATIONAL CONSTRUCTION CODE (NCC)

*Formerly known as BCA*

TWRAP™ has been tested extensively to AS1530.4-2014 and approved in accordance with AS4072.1 on a range of services and is suitable for use with Trafalgar Fire stopping systems. The key to fire testing is that you are testing a system and not a product. The system consists of:

- The service
- The fire barrier
- The fire stopping system

TWRAP™ forms only one part of the fire stopping system to help to reduce the heat transfer that occurs when testing thermally conductive services like metal pipes and cables.

As with all passive fire installations, the fire stopping system used must be installed as per the manufacturers instructions and test/assessment reports otherwise the penetrations may not be compliant. Please refer to each individual product manual for specific installation instructions which reflect how the systems have been tested and approved.

## TEST AND ASSESSMENT REPORTS

TWRAP™ test approvals have been incorporated into the fire assessment reports for each individual 'parent' fire stopping system. Our fire test and assessment reports for the above penetration systems, are available to download on the Test Reports page in the Knowledge Centre on our website [www.tfire.com.au/Test\\_Reports](http://www.tfire.com.au/Test_Reports):

- FyreFLEX® Sealant (FCO 1579)
- FyrePLUG® Pillows (FAS 200048)
- FyreBOARD MAXILITE® (FCO 3375)
- The FyreBOX™ range (FAR 10266)
- FyreSET® Mortar (FRT 200118 and FRT 200119)
- FyreBATT (FRT 180392 and FRT 190292)

***Compliance will only be achieved when the installation on site mirrors the tested system. Please refer to the 'parent' fire stopping system product manuals for specific installation instructions.***

# TWRAP™ CHOOSING THE RIGHT LENGTH OF TWRAP™

The required length of TWRAP™ is based on the FRL of the penetration, and the material properties of the services. For example, a copper pipe has higher thermal conductivity than a steel pipe and transmits heat faster, so copper pipes generally will need a longer amount of TWRAP™.

Refer to the product specific technical manuals for the correct width of TWRAP™ needed for each application.

## LARGER OPENINGS

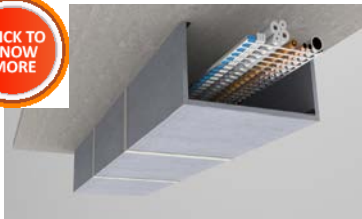

### FyreBOARD MAXILITE

Where you have larger openings around service penetrations or need to construct a fire rated bulkhead, FyreBOARD MAXILITE® is a versatile option and is compatible with a range of local fire stopping systems. FyreFLEX® sealant can be used to seal metal pipes and cables through FyreBOARD MAXILITE®, FyreCHOKE Collars for PVC pipes and conduits, and the FyreBOX™ Maxi and Mini systems for mixed services and/or insulated pipes. Once the services are sealed, TWRAP™ can be applied for the correct length as described in the FyreBOARD MAXILITE® product manual ranging from-/60/60 to-/240/240.



### FyreSET

For floor penetrations, FyreSET® mortar is suitable for cable bundles, cable trays and metal pipes where the penetration is formed up and infilled with mortar to provide a 4 hour penetration seal. Surface mounted systems are also approved. Once the services are cast-in place, TWRAP™ can be applied for the correct length as described in the FyreSET® Mortar product manual for FRL's ranging from-/90/90 to-/240/180.

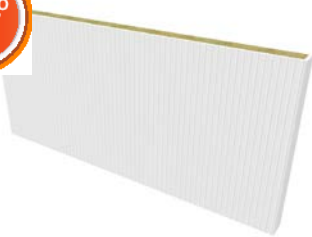

### FyreBATT

FyreBATT are simply cut to suit the profile of the penetration, and friction fit around cable tray penetrations to provide an effective fire seal in plasterboard walls and concrete floors when used with FyreFLEX® sealant. TWRAP™ can then be applied for the correct length as described in the FyreBATT product manual for FRL's ranging from-/90/90 to-/120/120.

# TWRAP™ CHOOSING THE RIGHT LENGTH OF TWRAP™

## SMALLER OPENINGS



The FyreBOX™ range is suited to huge range of service penetrations including multiple service types at once, including insulated pipes, plastic conduits, PVC and PEX pipes, cable trays and metal pipes. Available in a range of sizes and configurations to suit new construction (FyreBOX™ Slab Mount and Cast-In) or retro-fit applications (FyreBOX™ Maxi and Mini), once the services are sealed, TWRAP™ can be applied for the correct length as described in the FyreBOX™ product manuals for FRL's ranging from -/90/90 to -/240/180.



Suitable for cable bundles, cable trays and metal pipes, FyrePLUG® Pillows are simply hand packed around services inside a penetration to form a tight friction fit seal. Once the services are plugged and sealed with FyreFLEX® sealant, TWRAP™ can be applied for the correct length as described in the FyrePLUG® Pillows product manual for FRL's ranging from -/90/90 to -/240/180.



For simple metal pipe and cable bundles FyreFLEX® acrylic sealant is suitable for a wide range of penetrations including single and double layer plasterboard walls, 78mm Speedpanel®, 75mm Hebel®, masonry, concrete walls and floors. Once the services are sealed, TWRAP™ can be applied for the correct length as described in the FyreFLEX® product manual for FRL's ranging from -/60/60 to -/240/180.

# FyreFLEX® SEALANT

## METAL PIPES



TWRAP™ is required on metal pipes treated with FyreFLEX® Sealant in order to gain the full insulation value of the FRL. Depending on the pipe size and material, the length of TWRAP™ will change. See below for a brief overview of the lengths of wrap required, and refer to the full [FyreFLEX® Sealant technical manual](#) for the full details.

### WALL PENETRATIONS (OTHER THAN CONCRETE)

Services	Plasterboard 1 Hour	Plasterboard 2 Hour	75mm Hebel/Walsc (AAC)	78mm SpeedPanel®
FRL	-/60/60	-/120/120	-/90/90	-/120/120
Copper pipe (type B)	<b>TWRAP™ length required (both sides of the wall):</b>			
Up to DN50	300mm			
Up to DN100	450mm		600mm	
Up to DN 150	N/A	1100 & 300mm*	1050mm	1100 & 300mm*
Steel pipe (med)	<b>TWRAP™ length required (both sides of the wall):</b>			
Up to DN50	300mm			
Up to DN100	400mm		450mm	
Up to DN 150	N/A	900 & 300mm*	1050mm	900 & 300mm*

\*This indicates a second layer of TWRAP™ at the base of the penetration.

### CONCRETE WALLS AND FLOOR SLABS

Services	Concrete/masonry Floor Slab 2 Hour (min 175mm thick)	Concrete/Masonry Wall -/120/120
FRL:	-/120/120	-/120/120
Copper pipe (type B)	<b>TWRAP™ length required (both sides of the wall, or the top side only of a floor):</b>	
Up to DN50	300mm	
Up to DN100	600mm	
Up to DN 150	850mm	1100 & 300mm*
Steel pipe (med)	<b>TWRAP™ length required (both sides of the wall, or the top side only of a floor):</b>	
Up to DN50	300mm (-/120/120)	300mm
Up to DN100	450mm (-/180/180)	400mm
Up to DN 150	600 & 300mm* (-/240/180)	900 & 300mm*

\*This indicates a second layer of TWRAP™ at the base of the penetration.



# FyreFLEX® SEALANT

## ELECTRICAL CABLES

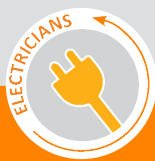

TWRAP™ is required on cable bundles treated with FyreFLEX® Sealant to gain the full insulation value of the FRL. Depending on the bundle size and the amount/type of cables, the length of TWRAP™ will change. See below for a brief overview of the lengths of wrap required, and refer to the full [FyreFLEX® Sealant technical manual](#) for the full details.

## WALL PENETRATIONS (OTHER THAN CONCRETE)

Services	Plasterboard 1 Hour	Plasterboard 2 Hour	SpeedPanel® 2 Hour	Hebel 90 Min	Concrete Floor Slabs	Concrete/ Masonry Walls 2 Hour
<b>Electrical</b>						
Small Data Cable Bundles*	None Required				None Required (-/120/120)	None Required
Other Data Cable Bundles	N/A	300mm			300mm (-/90/90)	300mm
Power Cable Bundles	N/A	300mm			450mm (-/120/120)	300mm
Cable Tray	N/A	300mm			450mm (-/120/120)	300mm
					450mm (-/180/180) Min 175mm Thick Slab	
					450mm & 450mm (-/240/240) Min 175mm Thick Slab	

\*Including a TPS, CAT6 and some power cables. Refer to [FyreFLEX® Sealant technical manual](#) for specifics.

# FyrePEX

## INTUMESCENT SEALANT



TWRAP™ is required on some penetrations treated with FyrePEX HP Intumescent Sealant to gain the full insulation value of the FRL. Depending on the service type and size, the length of TWRAP™ will change. See below for a brief overview of the lengths of wrap required and refer to the full [FyrePEX HP Intumescent Sealant technical manual](#) for the full details, as this does not reflect the full range of approved service (simply those that require wrap!).

Services	Plasterboard 90 Min	Hebel/Walsc AAC Panel 75mm	Plasterboard 2 Hour	SpeedPanel® 2 Hour	Concrete Floor Slabs 120mm
<b>HVAC&amp;R</b>					
Pair coil Bundles FR Insulated	None Required			300mm	None Required
Pair coil Bundles PE Insulated	300mm				

# FyreCOLLARS

## PLASTIC PIPES



FyreCHOKE Collars for plastic pipe penetrations do not required TWRAP™, however if FyreCHOKE Collars are used for insulated copper pair coil, TWRAP™ must be used to maintain the insulation value of the system FRL.

For all wall types 300mm of TWRAP™ must be applied to both sides of the wall. For Floors 300mm of TWRAP™ must be applied on the top side of the floor only.

For a full list of approved barriers and service configurations please refer to the [FyreCHOKE Premium Hinged Retrofit Collar technical manual](#).

# FyrePLUG® PILLOWS



For systems such as FyrePLUG® Pillows, where a substrate is used to close-down a larger opening, the TWRAP™ length can vary to what may be used for the same buildings service in another system. TWRAP™ is required on some penetrations treated with FyrePLUG® Pillows to gain the full insulation value of the FRL. Depending on the service type and size, the length of TWRAP™ will change. See below for a brief overview of the lengths of wrap required, and refer to the full [FyrePLUG® technical manual](#) for the full details.

Services	Plasterboard 2 Hour	SpeedPanel® 2 Hour	Hebel 90 Min	Concrete Floor 175mm
<b>Metal Pipes</b>				
Up to 100mm Copper or Steel	600mm	600mm & 300mm*		N/A
<b>Electrical Cables</b>				
Cable Trays	300mm	600mm		500mm
Small Cable Bundles**	None Required			

\*Indicates a second layer of TWRAP™ applied at the base of the penetration. \*\*TPS or CAT6 cables.

# FyreBATT FIRE RATED BATTS

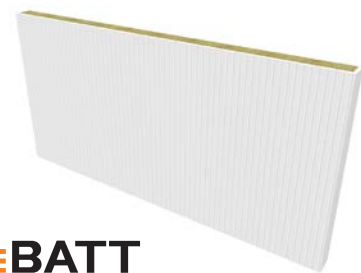

Other than FyrePLUG® Pillows, Trafalgar Fire has other penetration systems for instances where the opening may be too big. FyreBOARD Maxilite® and FyreBATT's are great options for a range of services. However, as they are approved for such a wide range of services, with a range of fire stopping details, summarising these lengths can be difficult. Refer to each product's report on the Trafalgar Fire website for this info: [www.tfire.com.au/Test\\_Reports](http://www.tfire.com.au/Test_Reports) or contact [technical@tgroup.com.au](mailto:technical@tgroup.com.au) for info.



# FyreSET®

## CONCRETE FLOOR SLABS



For large openings in concrete floor slabs, FyreSET® Mortar can be back-filled into the opening and set around the existing services, allowing you to form the correct sized openings for fire stopping. This system is ideal for situations with limited space available, as it sits within the opening and doesn't require overlaps onto the slab that other systems like Maxilite require. TWRAP™ is required on some penetrations treated with FyreSET® Mortar to gain the full insulation value of the FRL. Depending on the service type and size, the length of TWRAP™ will change. See below for a brief overview of the lengths of wrap required, and refer to the full [FyreSET® Mortar technical manual](#) for the full details.

Services	Thick Mortar Min 100mm		Thick Mortar Min 150mm	
FRL	-/90/90	-/120/120	-/90/90	-/120/120
<b>Electrical</b>				
Cable Trays	450mm		450mm	
Small Comms Cable Bundles*	No Wrap Required		No Wrap Required	
Power Cable Bundles**	No Wrap Required		No Wrap Required	
<b>Plumbing</b>				
Copper Pipes up to DN32	300mm	450mm	300mm	450mm
Copper Pipes up to DN50	450mm		450mm	
Copper Pipes up to DN80	600mm	800mm	600mm	800mm
Copper Pipes up to DN100	800mm		800mm	
Copper Pipes up to DN150	1200mm and 300mm	N/A	1200mm and 300mm	
Steel Pipes up to NB50	450mm		450mm	
Steel Pipes up to NB100	450mm		450mm	
Steel Pipes up to NB150	N/A	N/A	450mm	

Note: For 3-4 hour FRL's (-/180/180,-/240/240), contact [technical@tgroup.com.au](mailto:technical@tgroup.com.au) or refer the the [3-4 hour penetration technical manual](#).

\*Up to 10 x TPS, CAT6 or Firesense. \*\*Single 53mm OD 630mm<sup>2</sup> Single Core Cables, up to 3 x 42mm OD 180mm<sup>2</sup> 3C&E Cables, or up to 8 x 20mm OD Power cables.

# INSTALLATION



Measure the length of TWRAP™ required for your service type ensuring that you account for a 50mm overlap.



Cut the TWRAP™ to length using a sharp knife or scissors. Tape up any cut edges of TWRAP™ with re-enforced aluminium foil tape.

## CUT LENGTHS TABLE

We've taken some common and cables tray sizes, and tabulated the lengths required to wrap around each one, including enough length for the 50mm overlap. Please note that the length required along the length of pipe is service and application dependent, please refer to individual 'parent' fire stopping product manuals for specifics.

TWRAP™ cut length (mm)					
Pipe Diameter		Cable Trays		FyreBOX™ Range	
32	350	100	400	100	570
50	415	200	600	350	1050
80	510	300	800	550	1450
100	570	400	1000	650	1650
125	650	500	1200	750	1850
150	730	600	1400	1100	2550

# INSTALLATION

## WRAP - GENERAL



Wrap the TWRAP™ around the service, ensuring there is a minimum 50mm overlap between any overlapping sections of wrap.

## WRAP CABLES



For cable tray penetrations, voids in the cable tray must be filled with loose TWRAP™ infill material as shown in photo above (This is not required for bundles of cables not installed on cable trays).

*Cut or torn sections of TWRAP™ can be repaired with foil tape, as long as the infill material is still in place. TWRAP™ can be wrapped around existing pipe hangers and cable tray supports. Simply slit the TWRAP™ to fit around the service supports and tape over the joins.*

## WRAP PIPES



Floor penetrations require TWRAP™ to be applied to the top side only, whereas wall penetrations require fire rating from both directions, so TWRAP™ is required to both sides of the wall.

## STRAP



Strap in place with minimum 4.6mm wide steel cable ties, every 150mm and at every overlap where you are using more than one width of TWRAP™. Cable ties may be joined to create longer ties.

Do not overtighten the ties as this will cut the TWRAP™, aim to achieve 5mm of compression into the TWRAP™ blanket.

## SYSTEM RANGE



Item Number	Description	Min Order Qty	Pallet QTY
TWRAP 300	300mm wide, 25mm thick blanket	7620mm long roll	24
TWRAP 450	450mm wide, 25mm thick blanket	7620mm long roll	12
TWRAP 600	600mm wide, 25mm thick blanket	7620mm long roll	12

\* FyreWrap® can be substituted for TWRAP™

*TWRAP™ can be supplied in pre-cut sections for FyreBOX™ Slab-Mount applications and large projects. Contact Trafalgar Fire for more information.*

## SYSTEM COMPONENTS



Item Number	Description	Min Order Qty	Pallet QTY
Tape	Foil tape, 95mm wide, 50m roll	1	N/A
Cable Tie SS 12 x 521	4.6mm wide x 521mm long	25	N/A
Cable Tie SS 12 x 910	4.6mm wide x 910mm long	25	N/A

# DOCUMENTATION, MAINTENANCE AND ACCESS

Passive fire penetration registers are important on all modern building sites as they provide a central location for the site to document each passive fire system that has been used. This allows for the building certifier to check each system before issuing the occupancy certificates, and they are also used for periodic fire safety inspections throughout the life of the building.

TWRAP™ does not require any active or ongoing maintenance, however all passive fire penetrations are required to be inspected under AS1851 requirements, so it is good practice to document all penetration work thoroughly. As the installation of TWRAP™ can hide the local fire stopping systems below the wrap, Trafalgar Fire strongly advise to take photographs of the penetration work before and after TWRAP™ has been applied.

As AS1851 requires periodic inspections for all passive fire penetrations, the provision of access needs to be allowed for. TAccess is a dedicated business unit in the Trafalgar Group that specialises in Australian Made access panels and hatches, and can supply range of fire rated, acoustic, metal and customwood MDF access panels to suit your project requirements. Head to [www.taccess.com.au](http://www.taccess.com.au) for the full range of locally made access panels.



FyreSHIELD

hebel  
The better way to build

SPEEDPANEL  
THE QUALITY CHOICE FOR FIRE RATED WALL PENETRATIONS

# FIRE RATED WALL ACCESS PANEL



**NEW Website**

**CLICK TO KNOW MORE**

Find the right Access Panel for your needs!

TRAFALGAR ACCESS



# WHAT ABOUT FYREWAP®?



## FyreWrap®

FyreWrap® is a 38mm thick foil blanket which is traditionally used to fire rate ductwork, and to treat penetrations since the NCC change in 2008 when restrictions for insulation waivers for penetrations on site where tightened. Since this change occurred and wrapping penetrations has become common place, Trafalgar Fire has been listening to the market and has engineered down the wrapping specifications to deliver a thinner and easier to install material.

- FyreWrap® has now been superseded by the thinner and easier to install TWRAP™ system for penetration systems
- FyreWrap® can still be used to wrap service penetrations at the same length required for the TWRAP™ test approvals.

FyreWrap® will continue to be used for many other applications, for example; fire rating ductwork and the protection of copper hydrant ‘critical services’ applications. Contact Trafalgar Fire for more information or visit our website for more information on these applications.



## MORE ABOUT TWRAP™

TWRAP™’s core material incorporates the highly engineered, lightweight and high temperature thermal insulation material Insulfrax®. Insulfrax® is a high-temperature insulation made from calcia, magnesia and silica chemistry, designed to enhance bio solubility.

TWRAP™’s aluminium foil, fiberglass-reinforced outside layer completely encapsulates the core and provides additional handling strength, protection from tearing and most importantly provides a high resistance to mould growth.

Importantly, it also allows ease of identification of TWRAP™ in the field by building certifiers and engineers. TWRAP™ has undergone extensive testing to ensure it meets the highest quality in terms of environmental impact and health. The material is a completely bio-soluble solution and TWRAP™ has been Greenguard listed for microbial (mould growth) resistance.

Trafalgar Fire has engineered down the 25mm thick TWRAP™ installation requirements through fire testing to provide a significant improvement over the previous FyreWrap® 38mm thick blanket system, by testing more user friendly “off the shelf” size cable ties, and reducing the amount of sealant needed for penetration works.

Key benefits to installers, contractors, architects, engineers and certifiers are:

- Fast, clean and easy installation
- Improved installation details for faster application
- TWRAP™ lengths are service dependent, so smaller penetrations will use less material
- Lightweight
- Simple repair – tape up or replace sections
- Tested for mould-resistance
- Vibration tolerant
- Tested to AS1530.4-2014
- Compatible with Trafalgar Fire systems; FyreBOARD MAXILITE®®, FireBOX, FyrePLUG®, FyreFLEX®, FyreBATT and FyreSET® penetrations.



# SPECIFICATIONS



	Thickness	25mm
	Width	300/450/600mm
	Roll Length	7620mm
	Radial overlap required	50mm
	Material Density	128kg/m <sup>3</sup>
	Roll Weight (Net)	17kg / 34kg
	Microbial Resistance	GREENGUARD Certified as highly resistant to mould growth
	Bio-soluble	Yes
	Green Building Council/ LEED accreditation	Approved
	Contains Volatile Organic Compounds (VOC)	No
	Cable ties	4.6mm wide stainless steel
	Tape	Foil re-enforced aluminium tape

*TWRAP™ can be supplied in pre-cut sections for FyreBOX™ Slab-Mount applications and large projects. Contact Trafalgar Fire for more information.*



# HEALTH & SAFETY

The bio-persistence of the fibres in the core TWRAP™ product was identified after short-term exposure by inhalation in a study (No. 02G97008) by the European Ceramic Fibres Industry Association. As a result TWRAP™ core material is bio-soluble, and is completely safe for installers and anyone handling or coming into contact with the product.

TWRAP™ has also had microbial resistance testing completed by Green Guard and Air Quality Services. TWRAP™ was supplied, without any pre-conditioning, and relevant material samples were inoculated with spores of *Penicillium brevicompactum* and transferred to a static control environment chamber maintained at 95% humidity and 25°C.

This makes TWRAP™ resistant to mould colonisation, and perfect for environments such as hospitals, nursing homes and restaurant kitchens in which any type of mould grouping or activity could have severe consequences.

The below chart demonstrates TWRAP™’s resistance to mould growth.

### Microbial Growth Trends at 95% Humidity

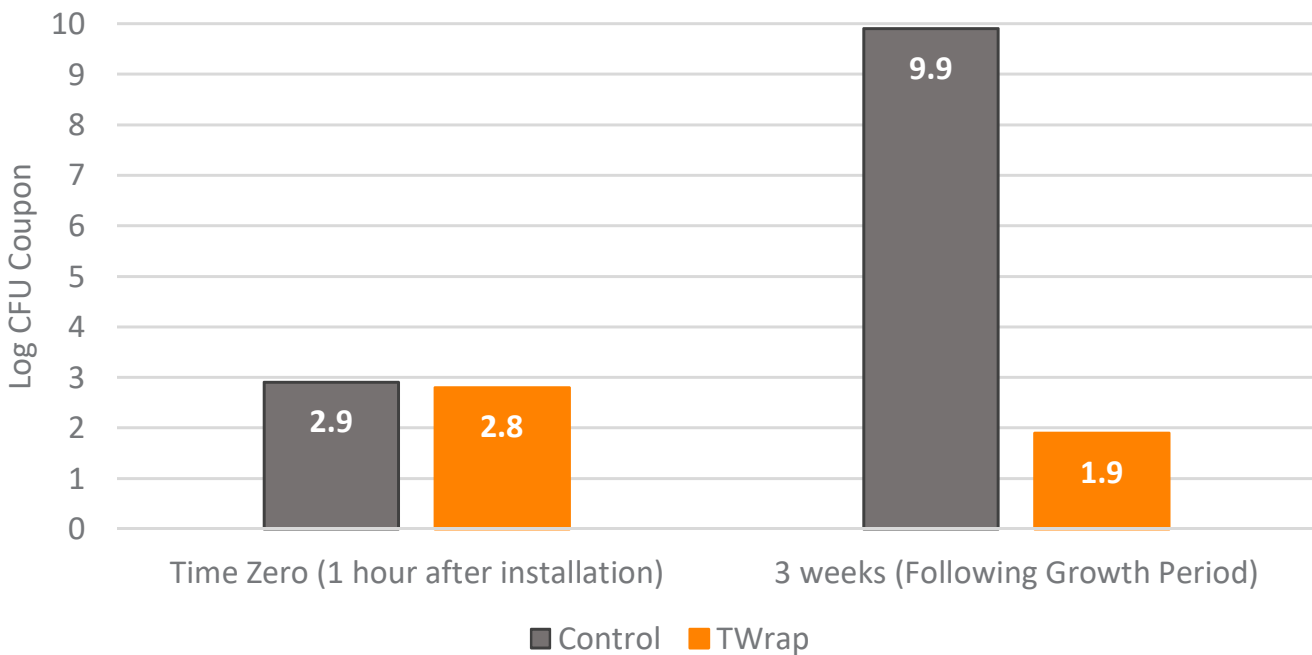

## TWRAP™ INSULATIONS SYSTEMS TO SUPERSEDE FyreWrap® 450MM AS OF JUNE 1ST 2020

On behalf of Trafalgar Fire, it is my pleasure to officially announce the release of our new TWRAP™ service penetration insulation systems, which feature improved/reduced installation requirements, tailored wrap lengths, and a greater range of approvals for more applications. Most importantly, the new TWRAP™ systems are tested in accordance with AS1530.4-2014 and ready for the National Construction Code (NCC) 2022 requirements.

It is important to note that existing FyreWrap® 450mm installations remain compliant under FCO 3024A as long as they were installed on or before the 31st of May 2020. Under our new TWRAP™ approvals, FyreWrap® may be substituted for TWRAP™ to assist in a smoother transition period for sites already using the FyreWrap® material, however the updated wrap lengths of the TWRAP™ system will apply.

The new TWRAP™ systems feature:

- Reduced thickness, at 25mm thick.
- Off-the-shelf steel cable ties.
- Reduced wrap lengths in a lot of applications (including some new wrap-free systems).
- Removed the need seal the base of the wrap to the fire barrier, resulting in significant labour and material reductions on site.
- Fully encapsulated and much easier to wrap.

Our growing library of testing has shown that the length of TWRAP™ needed to reduce the heat rise through a fire barrier is very specific to each application, including the wall or floor element as well as the service size and type. As a result of this, our TWRAP™ length specifications are not a simple uniform ‘one size fits all’ rule like its predecessor.

For most applications, we have found the following:

- Smaller cable penetrations can be wrap-free or treated with 300mm, with 450mm length covering larger cable trays as needed.
- Smaller metal pipes (copper under DN50 and steel under NB100) will require 300mm to 450mm lengths of TWRAP™ to achieve insulation performance of 2 hours.
- Larger metal pipes require longer lengths of wrap than previously approved

**Trafalgar Fire are committed to communicating this change of specification to the installers, builders, architects and certifiers and we encourage them to review the new information available in the TWRAP™ Product manual, and associated parent penetration system product manuals. We recommend that our customers adopt the new wrap lengths immediately on site to ensure a smooth transition to the new reports.**

To provide some background, the insulation rating of an FRL measures the time it takes for a building element to increase in temperature past 180 degrees on the non-fire side of a fire barrier, and is measured through fire testing to AS1530.4 through a series of thermocouples placed on the surfaces of the test specimen. When the National Construction Code or NCC (formerly known as BCA) changed over 10 years ago, it included a reduction to the waivers given for the insulation criteria for service penetrations, specifically around cable services but also metal pipes.

As an effective solution to a complex thermal problem Trafalgar Fire introduced an NCC compliant insulation system, using 38mm FyreWrap® insulation blanket approved through report FCO 3024a with a uniform ‘450mm’ wrap length.

TWRAP™ will be available in 300mm wide rolls from June 1st 2020, and the FyreWrap® rolls will still be readily available for the foreseeable future as we look to eventually bring in a TWRAP™ 450mm roll (due to COVID-19 disruptions our plans to do this sooner have been pushed back slightly). Pricing lists will be updated and issued over the next few weeks to our account customers to reflect these new TWRAP™ systems, and any sales enquiries should be directed to sales@tfire.com.au.

If you have any questions on this new and exciting system update, please feel free to contact me at [technical@tgroup.com.au](mailto:technical@tgroup.com.au).



John Henry  
**National Technical Manager**  
 Trafalgar Group

# FAQ

**Q What length of TWRAP™ do I need for my cable penetration?**

**A** 300mm to 450mm, depending on the size of the cables, the orientation of the fire barrier and the local fire stopping system used. Refer to the product manual of the local fire stopping for application specific wrap lengths.

**Q What length of TWRAP™ do I need for my metal pipe penetration?**

**A** For copper or steel pipes up to DN50, 300mm of TWRAP™ is suitable for most applications. For larger pipes, the length varies depending on the local fire stopping system used. Refer to the product manual of the local fire stopping for application specific wrap lengths.

**Q Can I use plastic cable ties?**

**A** No, minimum 4.6mm stainless steel cable ties should be used 50mm from each end of the TWRAP™, and at 150mm centres in-between.

**Q Can I use FyreWrap® instead of TWRAP™?**

**A** Yes, FyreWrap® can be used, when installed at the same length as required for TWRAP™. Refer to the product manual of the local fire stopping for application specific wrap lengths.

**Q Do I need to seal the base of the TWRAP™ with mastic sealant?**

**A** No, sealant or mastic is not required as part of the TWRAP™ installation (although is usually required as part of the local fire stopping system underneath).

**Q Do I have to cut back the steel cable tray from the penetration?**

**A** In most cases no, however refer to the parent penetration product manuals for specific approvals. For example, the FyreFLEX® sealant product manual will detail what size cable trays are tested and approved for use, as well as the length of TWRAP™ required.

**Q Do I need to wrap under a floor slab?**

**A** No, TWRAP™ has been tested specifically as a top side installation system for floor penetrations.

**Q How do I fix TWRAP™?**

**A** 4.6mm stainless steel cable ties, 50mm from each end of the TWRAP™ and at 150mm centres between them.

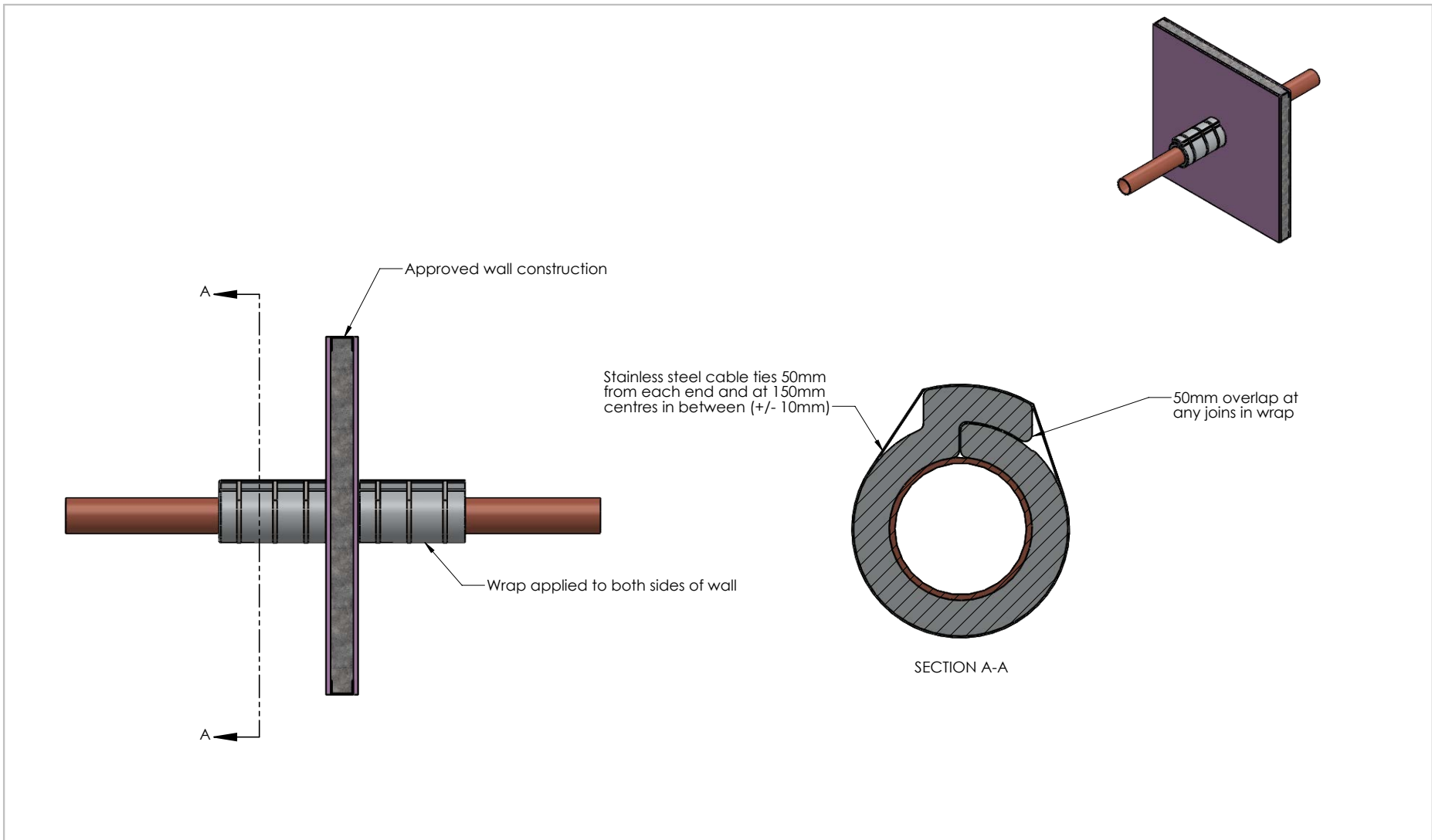

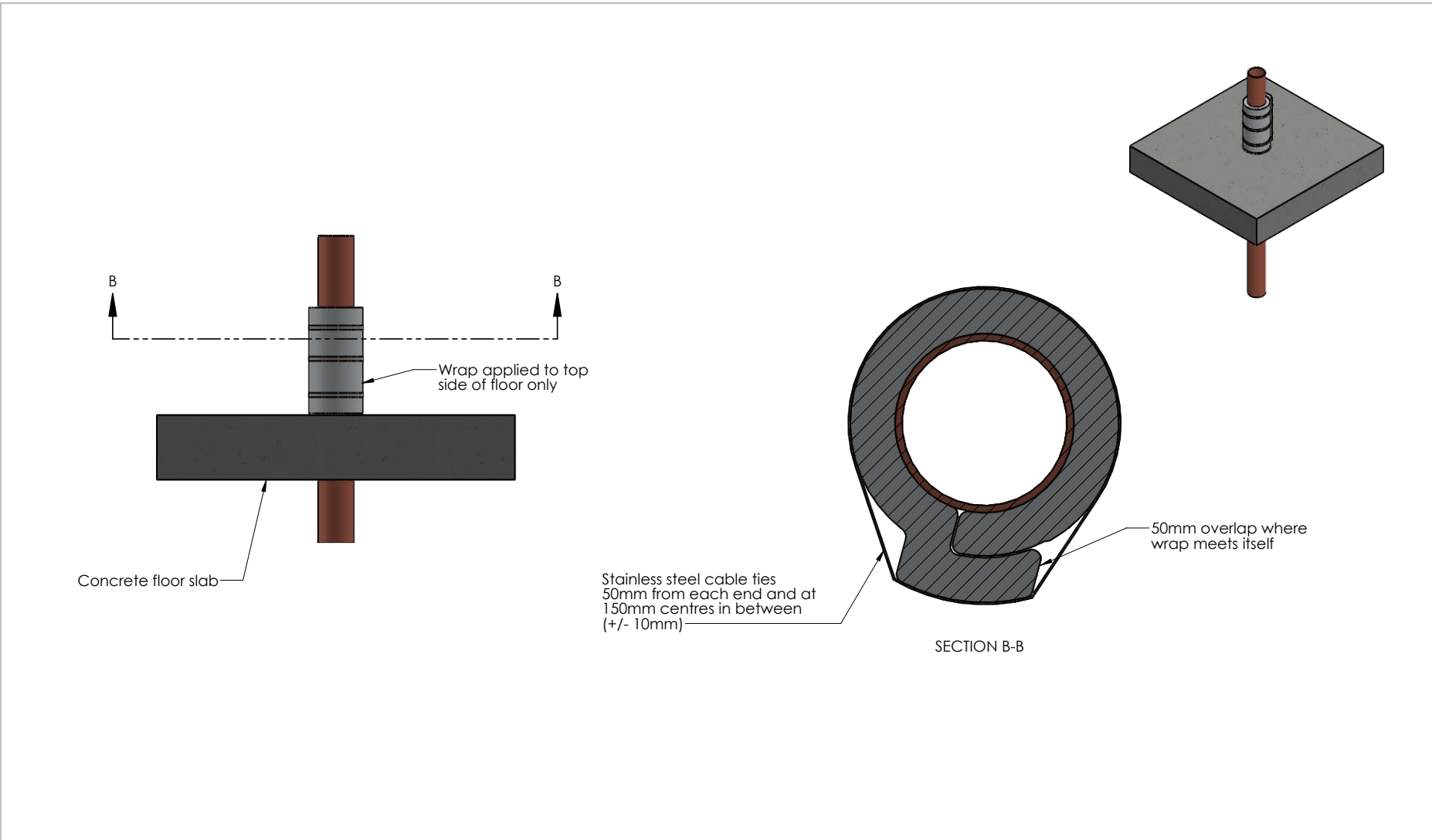

<b>Drawing Name:</b> Walls - Single TWrap Length				<b>Test Standard:</b> AS1530.4	<b>Codes:</b>	<b>Revision:</b>	<b>Date:</b>	<b>No.:</b>	<b>NOTICE:</b>
<b>Project Title:</b> TWrap FCO1579				<b>Fire resistance level:</b>	<b>Drawn By:</b> SM	<small>NOTE: ALL DIMENSIONS ARE IN MILLIMETRES (mm)</small>			
<b>Drawing No. :</b> 1	<b>Sheet:</b> 1 of 4	<b>Date:</b> 2/06/2021	<b>Scale:</b> NTS	<b>Based on Report No.:</b>	<b>Checked By:</b> JH	<input type="checkbox"/> STANDARD DRAWING			<b>Trafalgar Head Office:</b> PO BOX 545 Chester Hill NSW 2162 T: 1800 888 714 F: 1800 201 500 E: technical@tgroup.com.au W: www.tfire.com.au
						<input type="checkbox"/> PROJECT DRAWING			



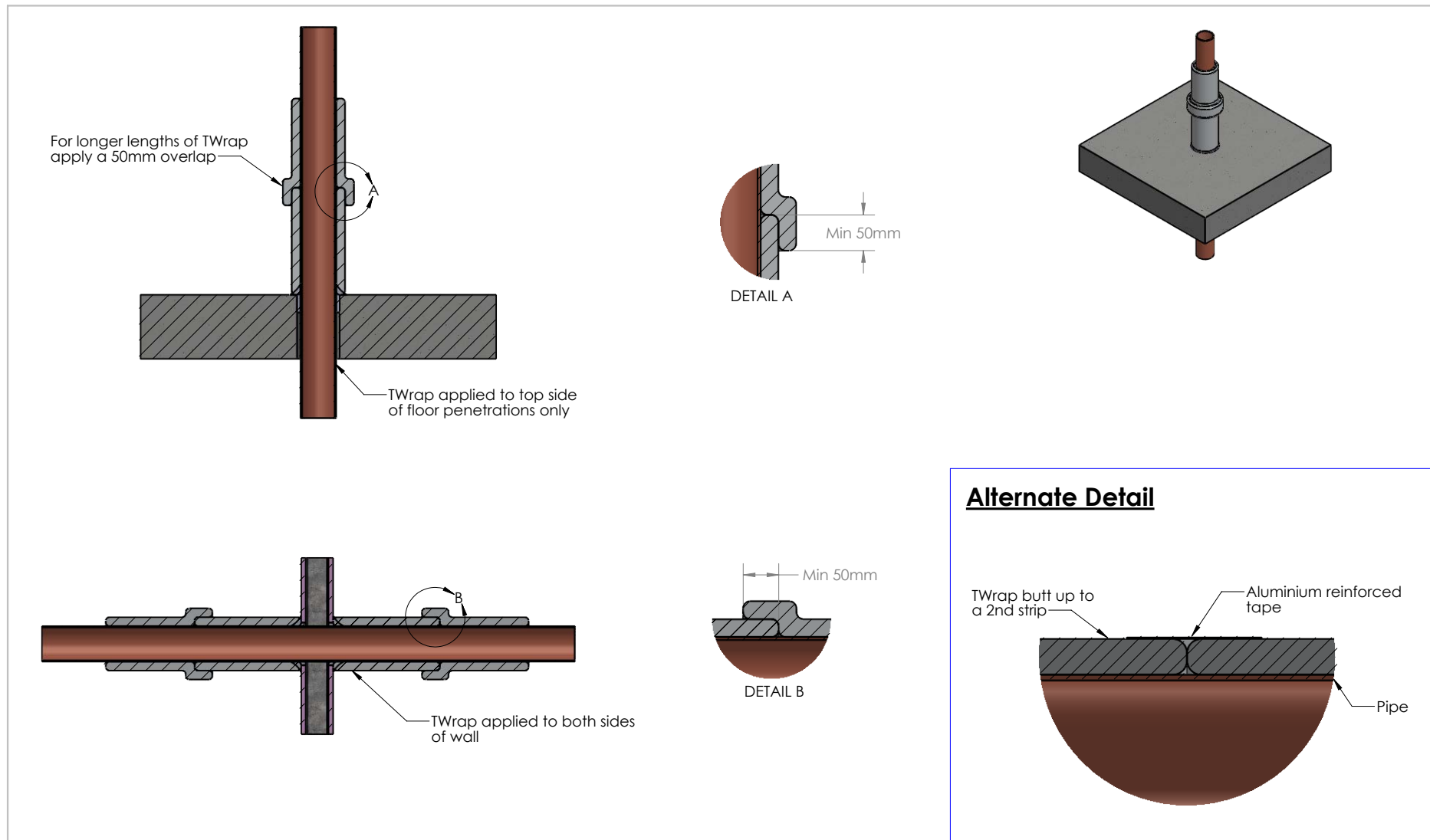

<b>Drawing Name:</b> Floors - Single TWrap Length				<b>Test Standard:</b> AS1530.4	<b>Codes:</b>	<b>Revision:</b>	<b>Date:</b>	<b>No.:</b>	<b>NOTICE:</b>
<b>Project Title:</b> TWrap FCO1579				<b>Fire resistance level:</b>	<b>Drawn By:</b> SM	<small>NOTE: ALL DIMENSIONS ARE IN MILLIMETRES (mm)</small>			
<b>Drawing No. :</b> 2	<b>Sheet:</b> 2 of 4	<b>Date:</b> 2/06/2021	<b>Scale:</b> NTS	<b>Based on Report No.:</b>	<b>Checked By:</b> JH	<input type="checkbox"/> STANDARD DRAWING	 <p><b>TRAFALGAR FIRE</b>                  Trafalgar Head Office:                  PO BOX 545                  Chester Hill NSW 2162                  T: 1800 888 714                  F: 1800 201 500                  E: technical@tgroup.com.au                  W: www.tfire.com.au</p>		
						<input type="checkbox"/> PROJECT DRAWING			



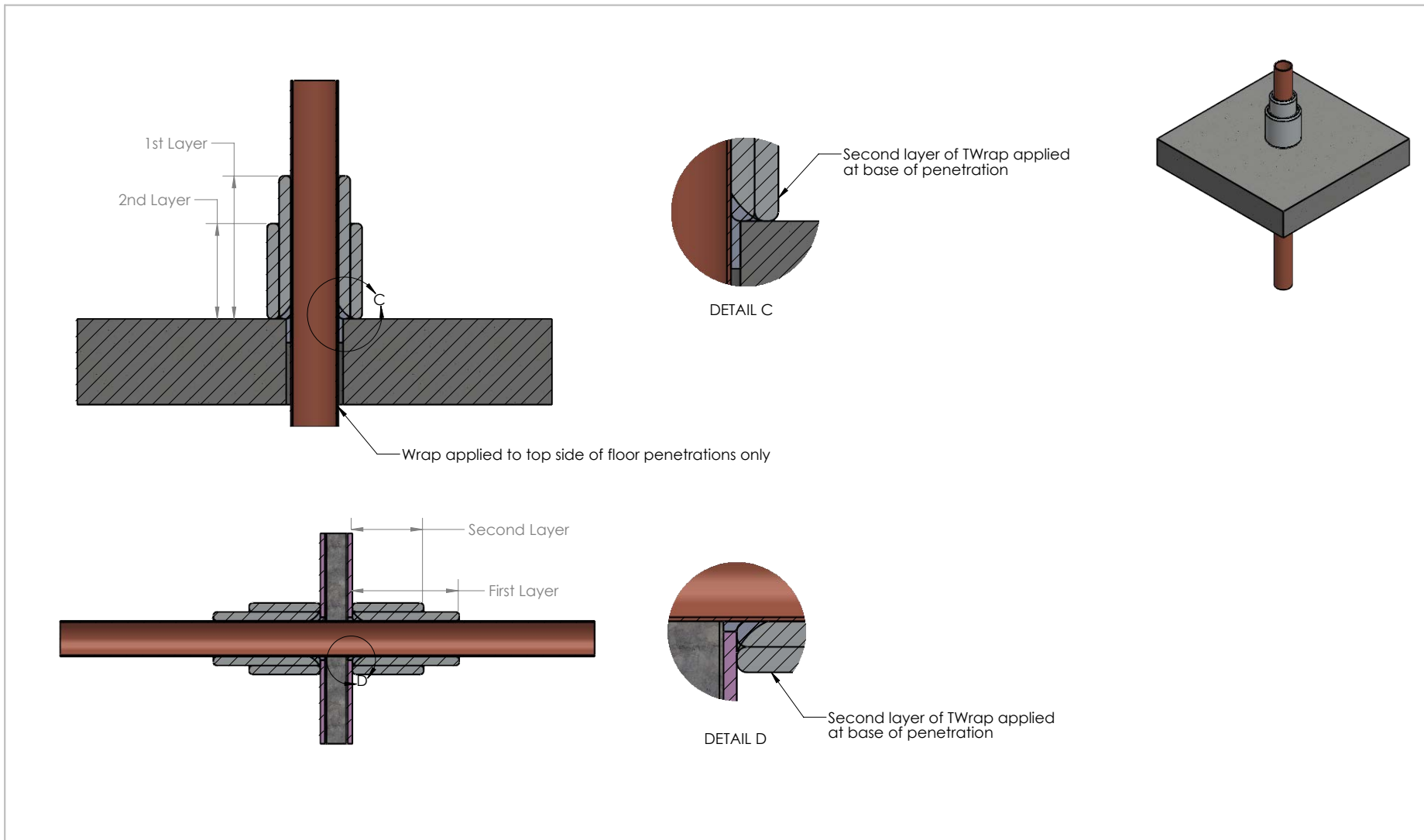

<b>Drawing Name:</b> TWRap - Extended Length				<b>Test Standard:</b> AS1530.4	<b>Codes:</b>	<b>Revision:</b>	<b>Date:</b>	<b>No.:</b>	<b>NOTICE:</b>
<b>Project Title:</b> TWRap FCO1579				<b>Fire resistance level:</b>	<b>Drawn By:</b> SM	<small>NOTE: ALL DIMENSIONS ARE IN MILLIMETRES (mm)</small>			
<b>Drawing No. :</b> 3	<b>Sheet:</b> 3 of 4	<b>Date:</b> 2/06/2021	<b>Scale:</b> NTS	<b>Based on Report No.:</b>	<b>Checked By:</b> JH	<input type="checkbox"/> STANDARD DRAWING	<input type="checkbox"/> PROJECT DRAWING	 <p><b>TRAFALGAR FIRE</b>                  Trafalgar Head Office:                  PO BOX 545                  Chester Hill NSW 2162                  T: 1800 888 714                  F: 1800 201 500                  E: technical@tgroup.com.au                  W: www.tfire.com.au</p>	



<b>Drawing Name:</b> Double Layers				<b>Test Standard:</b> AS1530.4	<b>Codes:</b>	<b>Revision:</b>	<b>Date:</b>	<b>No.:</b>	<b>NOTICE:</b>
<b>Project Title:</b> TWrap FCO1579				<b>Fire resistance level:</b>	<b>Drawn By:</b> SM	<small>NOTE: ALL DIMENSIONS ARE IN MILLIMETRES (mm)</small>			
<b>Drawing No. :</b> 4	<b>Sheet:</b> 4 of 4	<b>Date:</b> 2/06/2021	<b>Scale:</b> NTS	<b>Based on Report No.:</b>	<b>Checked By:</b> JH	<input type="checkbox"/> STANDARD DRAWING	<input type="checkbox"/> PROJECT DRAWING	 <b>Trafalgar Head Office:</b> PO BOX 545 Chester Hill NSW 2162 T: 1800 888 714 F: 1800 201 500 E: technical@tgroup.com.au W: www.tfire.com.au	