

DESCRIPTION

Ryanfire FS collars consist of a high quality stainless steel case lined with a highly reactive graphite infused material. The FS Collars are designed to maintain the fire resistance of fire rated walls for up to 120 minutes.

Upon exposure to heat the FS collar will quickly and effectively close any openings that may form due to the melting away of services.

CERTIFICATION

Ryanfire FS Collars have been tested and assessed in accordance with AS1530.4:2014 and AS4072.1:2005 at IANZ/NATA accredited laboratories.

APPLICATION

Ryanfire FS Collars have been tested for plasterboard, concrete and masonry walls on a range of combustible services including :

- uPVC
- PE-RT(KELOX)
- HDPE
- PPR
- Conduits

PRODUCT DIMENSIONS

Ryanfire FS Collars have been designed to fit most common services and come in the following sizes:

Code	FS 40	FS 55	FS 65	FS 82	FS 110	FS 125	FS 160
Collar Inside Ø mm	42	55	65	82	110	125	160
Collar Outside Ø mm	55	65	82	100	140	152	195
Collar Height mm	60	60	60	60	60	60	60
Fixing Lugs	4	4	4	4	4	4	6

NOTE: Sizes and dimensions are nominal.



Ryanfire FS Collar

Ryanfire FS Collars are usually used in conjunction with other Ryanfire products. Please contact the technical department for specific and more detailed "V" drawings.

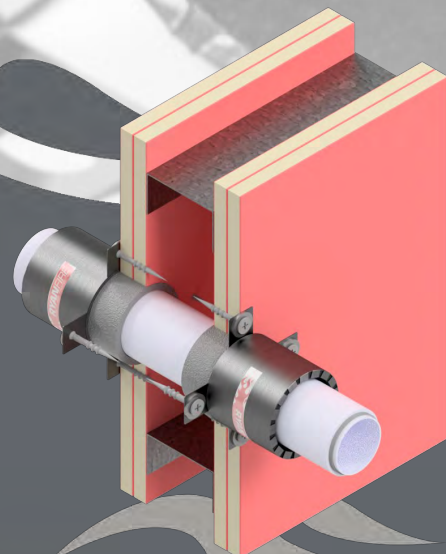
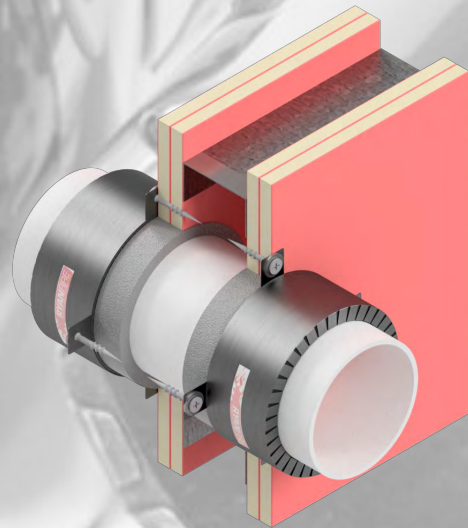

FEATURES

- Tested to AS1530.4:2014
- Standard sizes 40mm—160mm
- Stainless steel
- Retro fit capable
- Up to 120mins FRR

The information provided in this document is issued in good faith. As part of Ryanfire Products Ltd ongoing product development and testing, we reserve the right to modify product specifications without notice. Any drawings given are for illustrative purposes only. Ryanfire Products Ltd accepts no liability whatsoever for any loss, damage or injury arising from the misinterpretation or misuse of the information given. Subject to our standard terms and conditions.



For more information please contact Ryanfire
info@ryanfire.co.nz 09 443 0362